



CREATE

KEEPING THE GO IN CHICAGO

Get On Board

Business Presentation Session 2

April 28, 2021



Asking Questions

- Each of the Get On Board sessions, including this one, will be recorded to be shared online after the event
- Please stay muted with your camera off unless you are speaking
- You may submit questions through the Zoom Q&A feature
- Questions will be answered at the end of this session

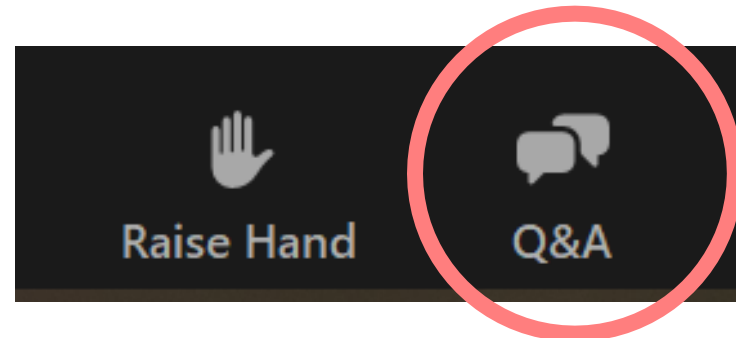

Itinerary

Wednesday:

2:00 p.m. – 3:30 p.m. Business Presentations Session 2

Confirmed Speaker: U.S. Congresswoman Marie Newman

Thursday:

10:00 a.m. – 11:30 a.m. Business Presentations Session 3 and Closing Remarks

The Zoom ID to enter each of the following sessions is:

961 6717 2186

Anyone who registered has this information in their calendar holds.

**The CREATE partners welcome
Representative Marie Newman**

A large target with concentric red and white rings is centered on a dark blue background. On the left side, four white darts with orange barrels and black shafts are scattered across the outer rings. On the right side, a cluster of five blue darts with orange barrels and black shafts is tightly grouped in the center bullseye. A horizontal grey bar with white text is overlaid across the middle of the target.

From Scattershot to

Focused

Defining Scattershot

Approach

- No plan
- Toe dipping
- Inconsistent

Wrong Audience/ Message

- Does not communicate your value
- Is not compelling



Services

Combining Creativity & Industry Knowledge

Brand | Identity

- Brand Strategy
- Naming + Taglines
- Visual Identity Systems
- Style Guides
- Brand Management

Print

- Direct Marketing
- Annual Reports
- Marketing Collateral
- ID Collateral
- Signage + Displays

Digital

- Digital Strategy + Marketing
- User Experience Design (UX/UI)
- Web Design + Development
- Mobile + Web Apps

Presentation | Video

- Art + Creative Direction
- Presentation/Sales Decks
- Video Development + Production
- Shoot Production



Client Sampling



Thank You

If you would like dig deeper into your brand to discover your unique brand position, call me at **773.588.0391** or email me at **Suzanne@carbon3sixty.com**.

For more information about us, visit **carbon3sixty.com**

April 28, 2021

Gannett Fleming

Overview

D. David Moses, PE

Dmoses@gfnet.com

312.617.1890



Excellence Delivered *As Promised* **ISO 9001:2015**
CERTIFIED

400⁺ 
RAIL
PROFESSIONALS

2,500⁺
PROFESSIONALS



**INNOVATIVE
PROJECT
SOLUTIONS
FOR MORE THAN
100
YEARS**



  
**SUSTAINABLE
PROGRESSIVE
SAFETY-FOCUSED**

\$500⁺
**MILLION
IN REVENUE**



**AEC FIRM SHAPING
INFRASTRUCTURE
THROUGHOUT
60 NORTH AMERICA
OFFICES**



#10 2020 *ENR* TOP 25 FOR
MASS TRANSIT & RAIL 



CREATE P1 Flyover



CREATE GS7 – Belmont Road Separation



Metra MD-N Z100



BNSF Bridge 261 over Tri-State



UPRR Bridge 3.49 over Ashland Ave

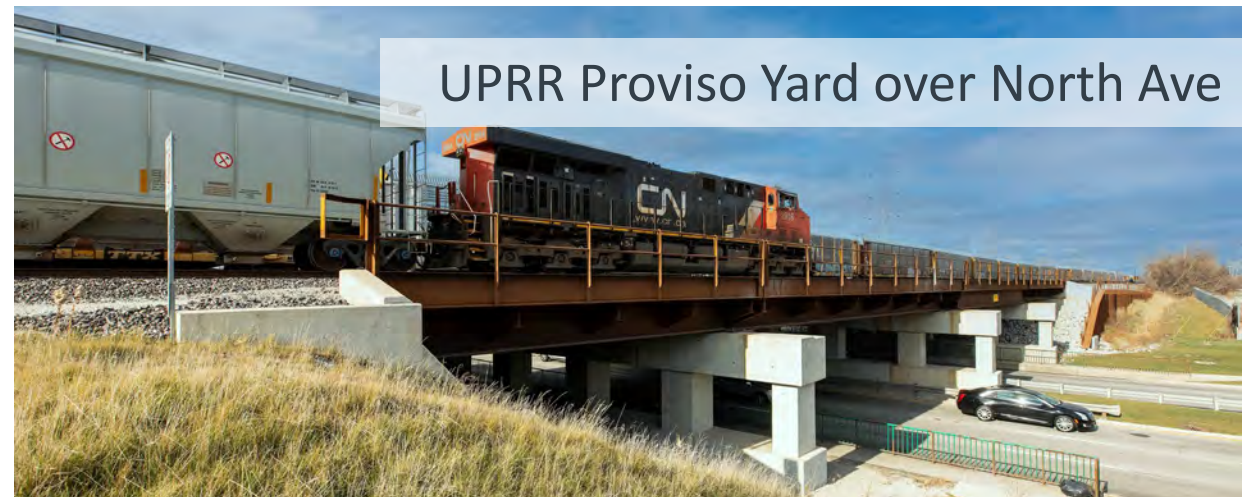

UPRR Proviso Yard over North Ave

DBE Commitment

Prime

- Graduated from the Program
- Teaming with GF as their strategic partner



Strategic Sub

- Gainful experience as discipline lead in key role
- Advisor to newer firms/DBE firms



Mentor Protégé

- Overall guidance & oversight
- Develop project management plan
- Develop QA/QC control plan
- Instruction on laws, regulations & rules
- Training in all business operations (e.g. invoicing, change order, SOI, etc.)



WHO WE ARE

Soteria specializes in **system safety and security planning from design through start-up**

- Analysis and Certification
- Reliability
- Ergonomics
- Organizational Assessment
- Emergency Preparedness
- Commissioning
- Start-Up
- Systems Engineering



AGENCIES



CLIENTS AND PARTNERS



WORK IN PROGRESS

- Metro Crenshaw/LAX Transit Corridor Project • Los Angeles, CA
- Redlands Passenger Rail Project • San Bernardino, CA
- LAX Automated People Mover Project • Los Angeles, CA
- Edmonton Valley Line LRT Project • Alberta, Canada
- Airport Metro Connector 96th Street Station Project • Los Angeles, CA
- Gold Line Foothill Extension Project • Los Angeles, CA



COMPLETED PROJECTS

Valley Metro System Design Services Project • Phoenix, AZ

Perris Valley Line Commuter Rail Extension Project • Perris Valley, CA

Mid-City/Exposition Light Rail Project • Los Angeles, CA

Metro Gold Line Eastside Extension Project • Los Angeles, CA



SOTERIA COMPANY, LLC

1637 266th Street, Harbor City CA 90710

Phone: 310.753.7470

Website: www.SoteriaCompany.com

LinkedIn: [Soteria Company LLC](#)

Tom Griego, Manager

Email: tom.griego@soteriacompany.com

Denise Stallcup, Business Development Manager

denise.stallcup@soteriacompany.com



2IM Group, LLC

Presented by:

Luis Montgomery, PE
2IM Group, LLC
luis.m@2imgroup.com
224-805-9926

- 1. Brief description of 2IM Group skills***
- 2. Track Experience***
- 3. Signals Experience***
- 4. Permitting***

2IM Group is a Civil Engineering and Environmental Services Firm. Our Experience includes working with Public Sector Agencies like Metra, CTA, IDOT, Illinois Tollway, etc. and Private Sector Clients including Union Pacific, Ameren Energy, and American Airlines.

Track Experience



RED PURPLE MODERNIZATION

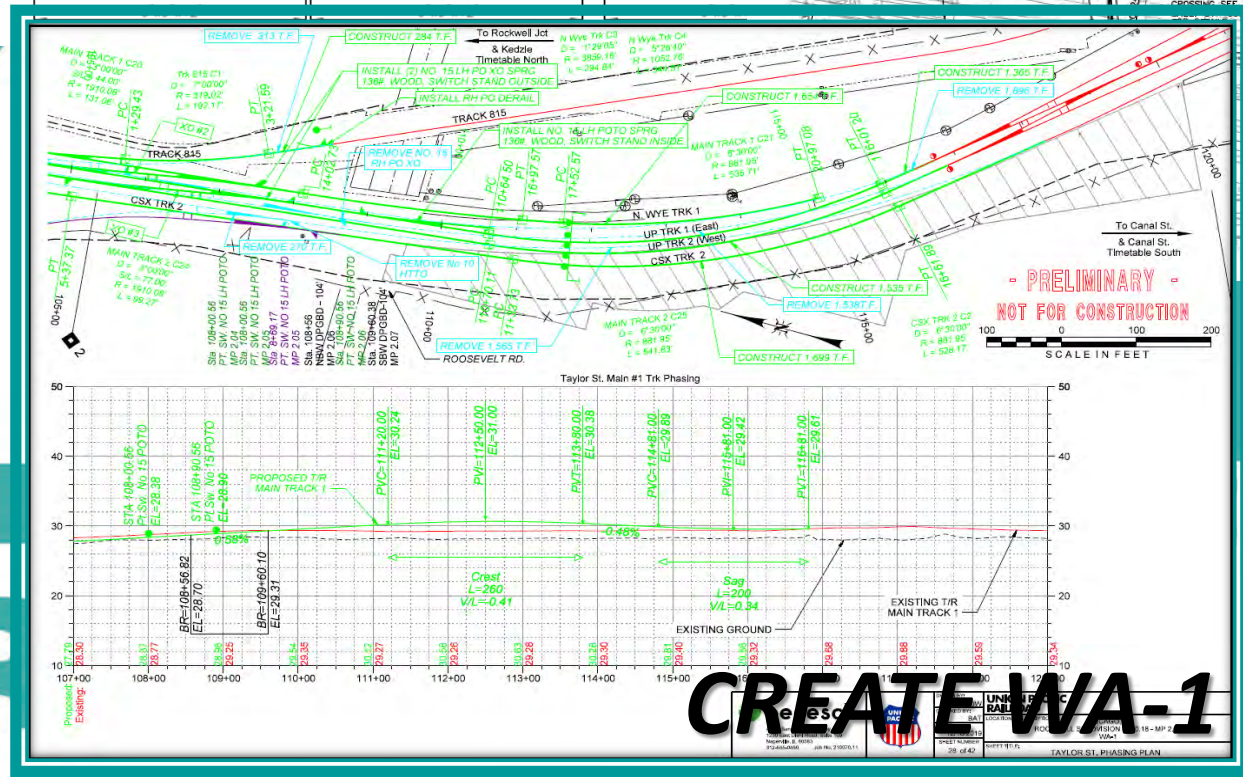
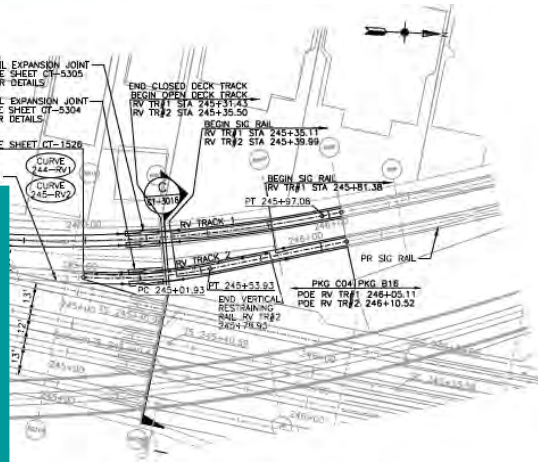
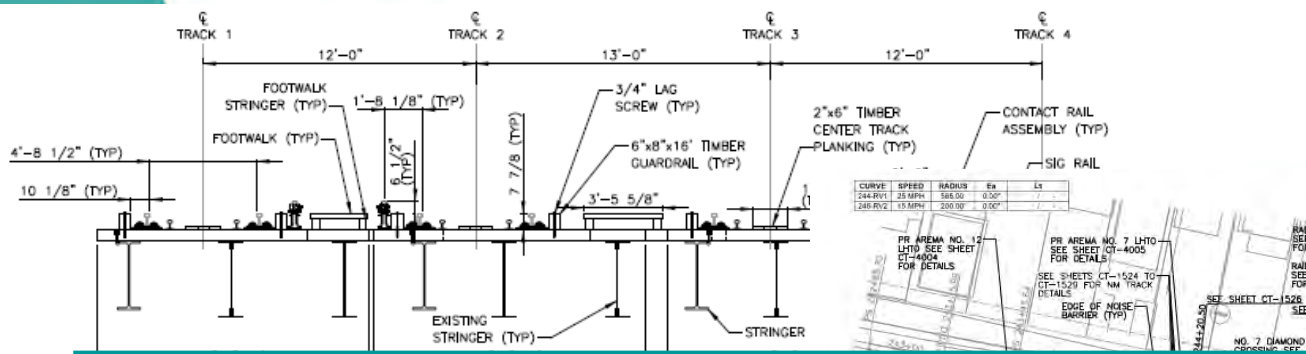

CREATE WA-1



TAYLOR ST. PHASING PLAN

Signals Experience



RED PURPLE MODERNIZATION

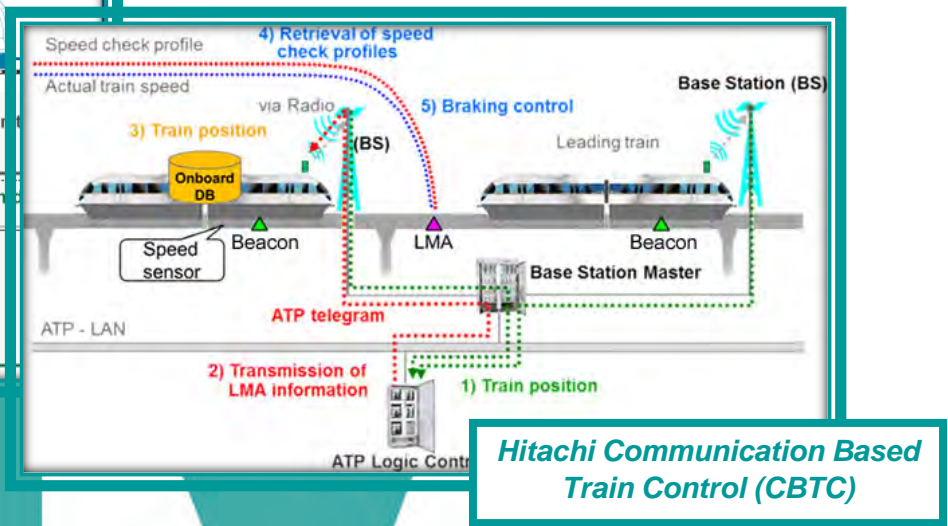
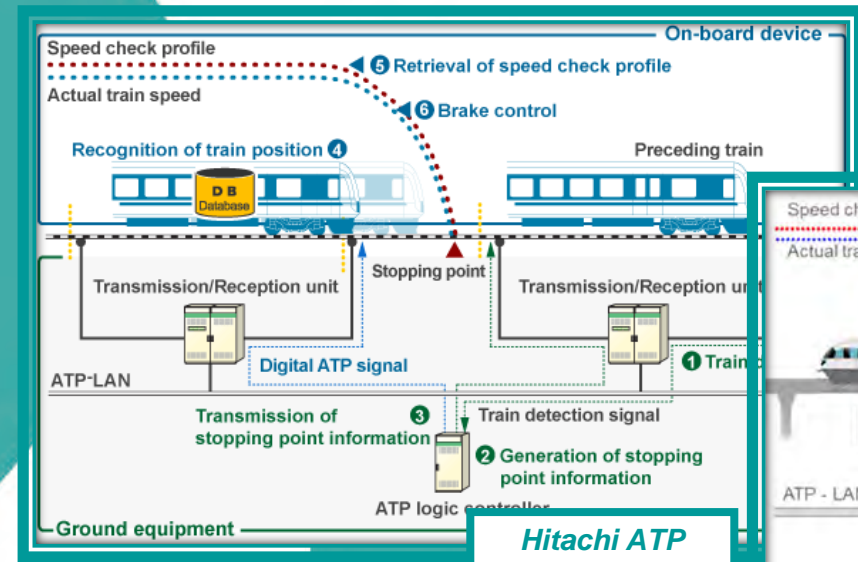

Vincent Bobade:

- *GIS Engineer with CN during PTC rollout*
- *Signals Engineer for CTA RPM Design-Build*

Permitting: Stormwater & Environmental



Fox Lake Station:

- *Drainage Design for station expansion*
- *Environmental Permitting (IEPA LPC-663)*

Rock Island District – Bridge #377 over Hickory Creek:

- *Hydraulic Model, Analysis, and Report*
- *Waters & Wetland Delineation*
- *USACE Permitting*
- *IDNR-OWR Permitting*

Van Buren Street Station Expansion:

- *Drainage design for new platform and pedestrian tunnel*
- *Chicago Department of Building – Stormwater Ordinance*



Presented by:

Luis Montgomery, PE

2IM Group, LLC

luis.m@2imgroup.com

312-508-5156

Questions?

- Reminder: each of the Get On Board sessions will be recorded to be shared online after the event
- If you have any questions now, please submit them in the Q&A box now
- If you have questions after this panel, please submit them at info@createprogram.org or through the Contact Us tab of the website createprogram.org

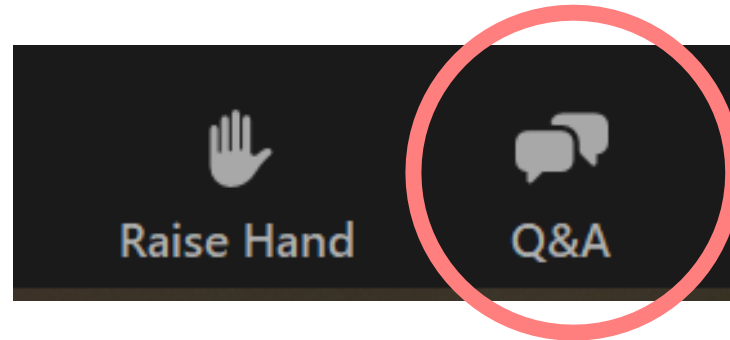

Panelist Contact Information

- Carbon3Sixty: Suzanne Carbon
 - suzanne@carbon3sixty.com and 773.588.0391
- Gannett Fleming: David Moses
 - dmoses@gfnet.com and 312.617.1890
- Soteria Company: Denise Stallcup
 - denise.stallcup@soteriacompany.com and 210.861.2739
- 2iM Group: Luis Montgomery
 - luis.m@2imgroup.com and 312-508-5156

Thursday:

10:00 a.m. – 11:30 a.m. Business Presentations Session 3 and Closing Remarks

The Zoom ID to enter the Thursday session is:

961 6717 2186

Anyone who registered has this information in their calendar holds.



Stay in Touch!

E-mail: info@createprogram.org

Website: createprogram.org



Like us on Facebook

[@CREATEProgramChicago](https://www.facebook.com/CREATEProgramChicago)



Follow us on Twitter

[@CREATE_Chicago](https://twitter.com/CREATE_Chicago)